

LUBRICATION ORDER

6 AUGUST 1985

**CLOTHING REPAIR SHOP, TRAILER MOUNTED
MODEL: CRS
NSN: 3530-01-133-3494
DARNING SEWING MACHINE
CHANDLER MODEL NO. 678HD**

Reference TM10-3530-205-14 and C9100-IL

Intervals (on-condition or hard time) and the related task-hour times are based on normal operation. The task-hour time specified is the time you need to do all the services prescribed for a particular interval. On-condition (OC) oil sample intervals shall be applied unless changed by Army Oil Analysis Program (AOAP) laboratory. Change the hard time interval if your lubricants are contaminated or if you are operating the equipment under adverse operating conditions including longer-than-usual operating hours. The hard time interval may be extended during periods of low activity. If extended adequate preservation precautions must be taken. Hard time intervals will be applied in the event AOAP laboratory support is not available.

Clean all lubrication points with dry cleaning solvent (SD), type II or equivalent. Dry before lubricating. The lowest level of maintenance to lubricate a point is indicated by one of the following:

(C) Operator/Crew or (O) Organizational Maintenance.

You can help improve this manual. If you find any mistakes or if you know of a way to improve procedures, please let us know. Mail your letter or DA Form 2028 (Recommended Changes to Publications and Blank Forms) direct to: Commander, US Army Troop Support Command, ATTN: AMSTR-MPS, 4300 Goodfellow Blvd, St. Louis, MO 63120-1798. A reply will be furnished to you.

LUBRICANT • INTERVAL

INTERVAL • LUBRICANT

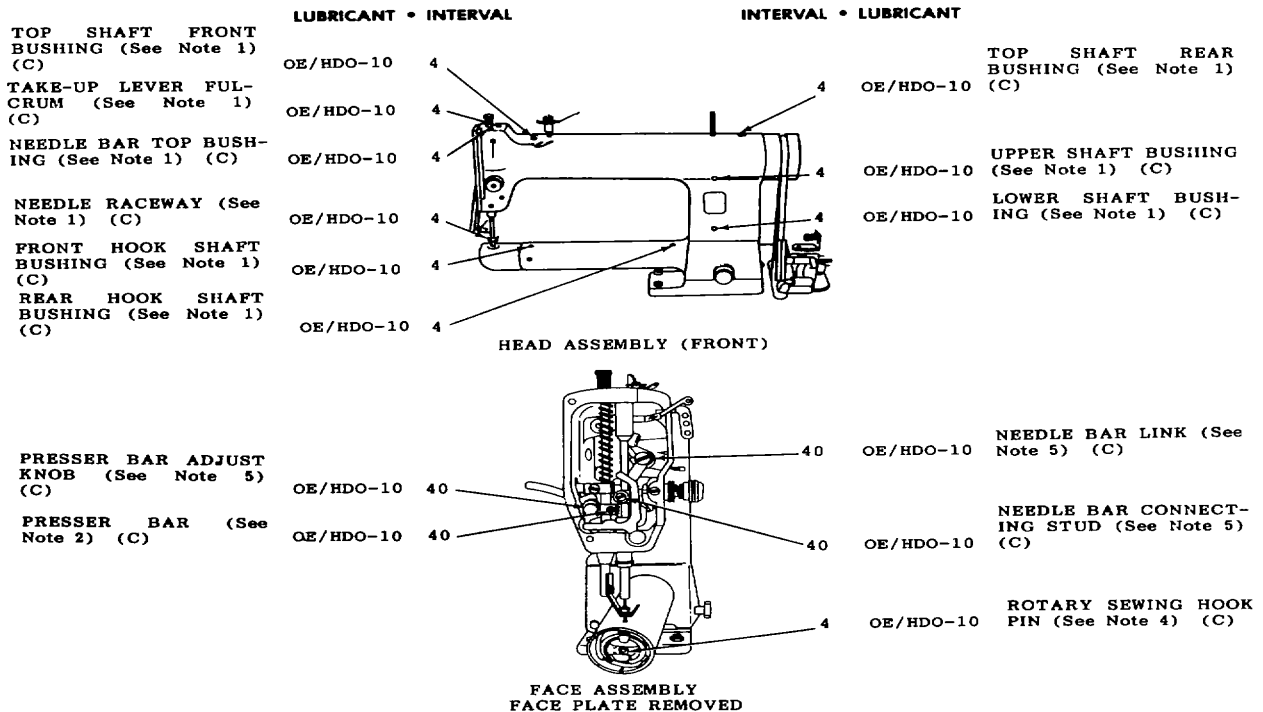

LUBRICANT * INTERVAL

INTERVAL * LUBRICANT

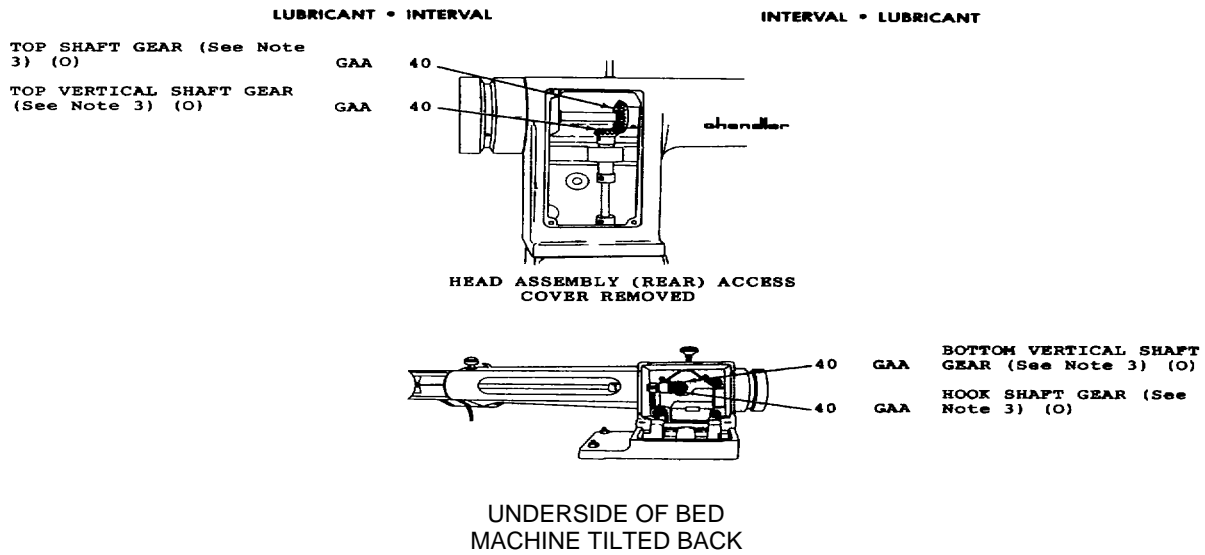

TOTAL TASK-HR		TOTAL TASK-HR	
INTERVAL	TASK-HR	INTERVAL	TASK-HR
4	1.0	40	1.0

LUBRICANTS		EXPECTED TEMPERATURES	INTERVALS
OE/HDO-10 (MIL-L-2104)	Lubricating Oil, General Purpose	All Temperatures	Intervals given are in hours of normal operation
GAA (MIL-G-10924)	Grease Automotive and Artillery	All Temperatures	

NOTES

1. Lubricate oil points with two or three drops of OE/HDO-10 every four hours.
2. Lubricate points with two or three drops of OE/HDO-10 every 40 hours.
3. Remove old grease and clean with dry cleaning solvent P-D-680. Allow to dry. Coat gear with GAA grease.
4. Remove bobbin. Lubricate pin. Reinstall bobbin.
5. Remove screws and cover. Lubricate. Reinstall cover and screws.

By Order of the secretary of the Army:

JOHN A. WICKHAM, JR.
General, United States Army
Chief of Staff

Official:

DONALD J. DELANDRO
Brigadier General, United States Army
The Adjutant General

DISTRIBUTION:

To be distributed in accordance with DA form 12-25A, Operator Maintenance requirements for Clothing and Textile Repair.

Copy of this Lubrication Order will remain with the equipment at all times, instructions contained herein are mandatory.

RECOMMENDED CHANGES TO EQUIPMENT TECHNICAL PUBLICATIONS



THEN... JOT DOWN THE DOPE ABOUT IT ON THIS FORM, CAREFULLY TEAR IT OUT, FOLD IT AND DROP IT IN THE MAIL!

SOMETHING WRONG WITH THIS PUBLICATION?

FROM: (PRINT YOUR UNIT'S COMPLETE ADDRESS)

DATE SENT

PUBLICATION NUMBER

PUBLICATION DATE

PUBLICATION TITLE

BE EXACT... PIN-POINT WHERE IT IS

IN THIS SPACE TELL WHAT IS WRONG AND WHAT SHOULD BE DONE ABOUT IT:

PAGE NO.

PARA-GRAPH

FIGURE NO.

TABLE NO.

TEAR ALONG PERFORATED LINE

PRINTED NAME, GRADE OR TITLE, AND TELEPHONE NUMBER

SIGN HERE:

DA FORM 2028-2 JUL 79

PREVIOUS EDITIONS ARE OBSOLETE.

P.S.—IF YOUR OUTFIT WANTS TO KNOW ABOUT YOUR RECOMMENDATION MAKE A CARBON COPY OF THIS AND GIVE IT TO YOUR HEADQUARTERS.

